

# 2 1/4 TON HYDRAULIC FLOOR JACK

Item Number W1611

## OWNER'S MANUAL



### **▲WARNING**

*It is the owner and/or operators' responsibility to study all WARNINGS, operating, and maintenance instructions contained on the product label and instruction manual prior to operation of this product. The owner/operator shall retain product instructions for future reference.*

*The owner and/or operator are responsible for maintenance, maintaining all decals or warning labels and while in use, maintaining the unit in good working order. If the owner and/or operator are not fluent in English, the product warnings and instructions shall be read and discussed with the operators' native language by the purchaser/owner or his designee. Make sure that the operator comprehends its contents. Safety information shall be emphasized and understood prior to usage. The product shall be inspected per the operating instructions.*

*Users of this product must fully understand these instructions. Each person operating this product must also be of sound mind and body and must not be under the influence of any substance that might impair their vision, dexterity, or judgment.*

*Protect yourself and others by observing all safety information.*

*Failure to comply with instructions could result in personal injury and/or property damage!*

*If you encounter any problems or difficulties, please contact our customer service department at: 1-800-426-1262 between 6:30 a.m. and 4:30 p.m. Pacific time.*

# SAFETY GUIDELINES / DEFINITIONS

This instruction manual is intended for your benefit. Please read and follow the safety, installation, maintenance and troubleshooting steps described within to ensure your safety and satisfaction. The contents of this instruction manual are based upon the latest product information available at the time of publication. The manufacturer reserves the right to make product changes at any time without notice.

**▲ WARNING:** Read and understand this entire instruction manual before attempting to assemble, install, operate or maintain this product. Failure to comply with the instructions may result in serious personal injury and/or property damage!

The following signal words are used to emphasize safety warnings that must be followed when using this product:

**▲ DANGER** Indicates an imminently hazardous situation that, if not avoided, **WILL** result in death or serious injury.

**▲ WARNING** Indicates a potentially hazardous situation that, if not avoided, **COULD** result in death or serious injury.

**▲ CAUTION** Indicates a potentially hazardous situation that, if not avoided, **MAY** result in minor or moderate injury.

**▲ NOTICE** Indicates important information, which if not followed, **MAY** cause damage to equipment.

After opening the carton, unpack your new product and related parts & accessories. Please inspect it carefully for any damage that may have occurred during transit. Please check it against the photograph on carton. If any parts are missing, please call customer service at 1-800-426-1262 between 6 a.m. and 5 p.m. Pacific time.

**▲ WARNING** DO NOT operate this product if damaged during shipment, handling or misuse. Do not operate the product until the parts have been replaced or the fault rectified. Failure to do so may result in serious personal injury or property damage. All damaged parts must be repaired or replaced as needed prior to operating this product. Check to see that all nuts, bolts and fittings are secure before putting this product into service. If you have any questions, or require assistance with damaged or missing parts, please contact our factory customer service department at: 1-800-426-1262.

Please have the serial number, model number, and date of purchase available for reference when calling.

# SPECIFICATIONS

**Capacity:**..... **4,500 lbs.**  
**Minimum Lift Height:**..... **5 1/4 in.**  
**Maximum Lift Height:** ..... **15 1/2 in.**  
**Base Length:** ..... **17 in.**  
**Base Width:**..... **8 in.**

**Specifications are subject to change without notice.**

# IMPORTANT SAFETY INFORMATION

**▲ WARNING**  
**READ, UNDERSTAND AND FOLLOW ALL INSTRUCTIONS AND WARNINGS BEFORE OPERATING THIS TOOL. FAILURE TO DO SO MAY RESULT IN PERSONAL INJURY AND/OR PROPERTY DAMAGE AND WILL VOID WARRANTY.**

**▲ Warning:** This is a lifting device only. Load must be supported immediately by Jack Stands.

1. Study, understand and follow all instructions before operating this device.
2. DO NOT exceed rated capacity. Overloading can cause damage to or failure of this product.
3. Use only on hard, level surface capable of sustaining the load. Use of jack on other than hard level surfaces can result in jack instability and possible loss of load.
4. Lifting device only. Immediately after lifting, support the vehicle with appropriate means. Ensure that no personnel pass underneath load until load is securely supported by jack stands.
5. DO NOT adjust safety valve.
6. Wear ANSI approved safety goggles and heavy duty work gloves during use.
7. Keep clear of load while lifting and lowering.
8. Lower load slowly.
9. DO NOT use for aircraft purposes.
10. Apply parking brake and chock tires before lifting vehicle.
11. Lift vehicle only at vehicle manufacturer recommended lift locations.
12. Inspect before every use; do not use if parts are loose or damaged.
13. Do not alter this product in any way.
14. Keep your work area clean and well lit. Cluttered work areas invite accidents.
15. Keep bystanders, children, and visitors away while operating this product. Distractions can cause you to lose control.
16. Stay alert. Watch what you are doing, and use common sense when operating this product. Do not use this product

# IMPORTANT SAFETY INFORMATION

while tired or under the influence of drugs, alcohol or medication. A moment of inattention while operating this product may result in serious personal injury.

17. Store idle jacks out of reach of children and other untrained persons. Jacks are dangerous in the hands of untrained users.
18. Tool/equipment service must be performed only by qualified repair personnel. Service or maintenance performed by unqualified personnel could result in a risk of injury.
19. When servicing this product, use only identical replacement parts - refer to attached, product-specific parts list and diagram. Follow instructions in the Care & Maintenance section of this manual. Use of unauthorized parts or failure to follow maintenance instructions may create a risk of injury and may void any applicable warranty.
20. Maintain labels and nameplates on this product. These carry important information. If unreadable or missing, contact Performance Tool for a replacement.
21. Before use, read manufacturer's instruction manual for the vehicle (or object) you will lift.
22. When lifting only one wheel, support the load immediately with one jack stand (not included) placed under the side of the vehicle being lifted. Align the saddle of the jack stand directly under the vehicle's frame or recommended lifting point.
23. When lifting the entire front end or rear end of a vehicle,

support the load immediately with two jack stands. Align the saddles of the jack stands directly under the vehicle's frame or recommended lifting points. Also, adjust the jack stands to the same height.

24. Do not work under the vehicle without properly supporting the vehicle with jack stands.
25. Avoid dangerous oncoming traffic. Use the Jack as far away from the roadside as possible.
26. Industrial applications must follow OSHA requirements.
27. Do not allow anyone inside the vehicle while using the Jack. Keep all bystanders a safe distance away from the vehicle.
28. Do not support both ends of the vehicle at the same time.
29. Before lowering the jack, remove all tools and equipment from under the vehicle.
30. The warnings, precautions, and instructions discussed in this manual cannot cover all possible conditions and situations that may occur. The operator must understand that common sense and caution are factors, which cannot be built into this product, but must be supplied by the operator.

**WARNING:** This product and its packaging contain a chemical known to the State of California to cause cancer, birth defects, or other reproductive harm.

# BEFORE USE

**▲ NOTICE** During shipment or handling, air in the jack can become trapped in the hydraulic system causing the jack to malfunction.

## Before using your jack:

1. Place pump handle over release valve and turn counter-clockwise no more than two turns to open.
2. Pump jack about 6 full strokes to ensure complete distribution of hydraulic fluid. (See Figure 1)
3. Repeat above steps as needed.

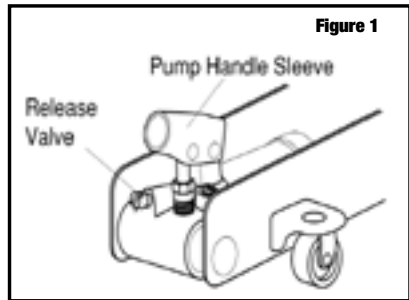

# OPERATION

## To raise:

1. Park vehicle on a hard level surface safely away from oncoming traffic.
2. Turn off the vehicle's engine.
3. Place the vehicle's transmission in PARK, if equipped with an automatic, or in its lowest gear, if equipped with a manual transmission.
4. Set the vehicle's emergency brake and block the wheels that are not being lifted.
5. Refer to vehicle owner's manual for proper jacking procedures. Lift only on areas of vehicle as specified by manufacturer.
6. Make certain that load is centered on saddle.

7. Place pump handle over release valve and turn clockwise to close.
8. Insert handle into handle socket and pump to raise load to desired height.

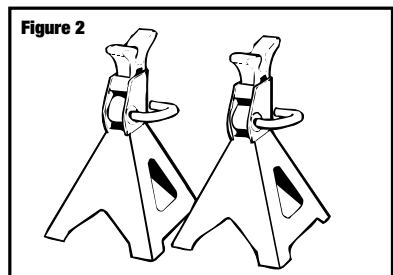

## OPERATION

9. ALWAYS support load with jack stands. (See figure 2) Place jack stands of appropriate capacity (not included) beneath the vehicle at locations recommended by the vehicle manufacturer. DO NOT Get under the vehicle without jack stands. Jacks are not designed to maintain heavy loads for long periods of time. DO NOT attempt to put jack stands simultaneously under both ends of vehicle or under one side of vehicle. NOTE: When using two jack stands, they must be at the same height.
10. SLOWLY turn the release valve counter-clockwise to lower vehicle onto jack stands and remove jack.

**IMPORTANT:** NEVER MOVE JACK WHEN THE HANDLE IS IN OPERATING LEVER OR THE VALVE SLEEVE. DAMAGE TO THE PUMPING UNIT MAY OCCUR.

## CARE & MAINTENANCE

Monthly maintenance is recommended. Lubrication is critical to jacks as they support heavy loads. Any restriction due to dirt, rust, etc. can cause either slow movement or cause extremely rapid jerks, damaging the internal components. The following steps are designed to keep the jack maintained and operational.

1. Before each use, inspect the general condition of the jack. Check for broken, cracked, or bent parts, loose or missing parts, and any condition that may affect the proper operation of the product. Any jack that appears damaged in anyway must be removed from service. Have the problem corrected before further use. DO NOT use damaged equipment.
2. Replace worn or damaged parts with Performance Tool replacement parts. Be sure that only qualified personnel perform repairs.
3. Before each use, thoroughly test the jack for proper operation prior to its actual use. If the jack appears not to be working properly, follow bleeding instructions on page 3.
4. When jack is not in use, ram and pump piston should be in fully down position to keep their machined surfaces free from corrosion.
5. Keep jack clean and well lubricated at points illustrated in figure 3.
6. For best results, use only hydraulic fluid with a rating of SAE 20 for refills. Check fluid level with jack in fully down position. Fluid level should be up to bottom of oil fill port. (See figure 4)
7. Change the hydraulic oil at least once every three years:
  - a. With the jack fully lowered, remove the oil filler plug on the side of the Housing.
  - b. Tip the jack to allow the old hydraulic oil to drain out of the Housing completely, and dispose of the old hydraulic oil in accordance with local regulations.
  - c. With the jack upright, completely fill the housing with a high quality hydraulic oil (not included) until the oil just begins to run out of the oil fill hole. Be VERY CAREFUL not to allow dirt or foreign matter into the system.
  - d. Then, reinstall the oil filler plug.
  - e. Clean with a clean cloth using a detergent or mild solvent. Then, store the jack in a safe, dry location with the ram and pump piston in fully down position. Keep out of reach of children and other non-authorized people.

### To lower:

1. Remove all tools, parts, etc. from under the vehicle.
2. Position the saddle under the lifting point. Place pump handle over release valve and turn clockwise to close the valve release screw, and pump the upper/lower handle to raise the vehicle slightly above the saddle(s) of the jack stands. Then, collapse and remove jack stand(s).
3. SLOWLY turn the release valve counter-clockwise with the handle just enough to allow controlled descent of the vehicle onto the ground. (Never more than two full turns).
4. Lower the jack completely. Then, store in a safe, dry location out of reach of children.

**Figure 3**

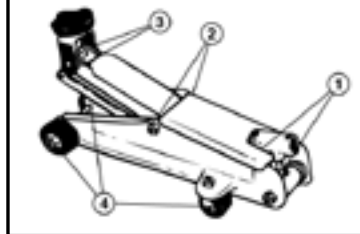

# TROUBLESHOOTING

Your Performance Tool® product was constructed with quality materials and workmanship and will give you many years of trouble free use when cared for as described in the "Care & Maintenance" section on page 4. However, as with any mechanical device, periodic adjustments are necessary to maintain a peak level of performance. Should your jack be displaying any of the following symptoms, the simple procedures shown below will correct the problem.

**▲ WARNING: Remove jack from service before making adjustments**

Will not lift load	●	●	●
Will not hold load			●
Will not lift to full height	●	●	
Pump feels "spongy" under load	●	●	
Handle raises under load			●
Handle lowers under load			●
	Power unit may be low in fluid. With jack on level surface and in down position, remove filler plug and add clean hydraulic jack fluid to level of filler.	Power unit may be air bound. Open the release valve a minimum of 2 full turns. Pump the handle a minimum of 20 full strokes to purge air from the system.	Valve may not be closing completely. To seat valves: a.) Close release valve. b.) With jack in fully lowered position, manually raise lifting arm as high as possible. c.) Open release valve and allow jack to descend to lowered position

**NOTE:**

Problems listed above with more than one solution may have a combination of causes. Please be sure that all solutions listed for each problem have been checked to eliminate possibility of further trouble. Sometimes solutions may need to be repeated for best results.

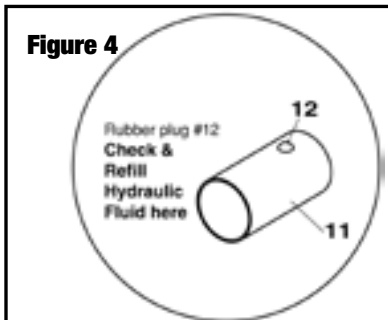

# REPLACEMENT PARTS LIST

Figure 5

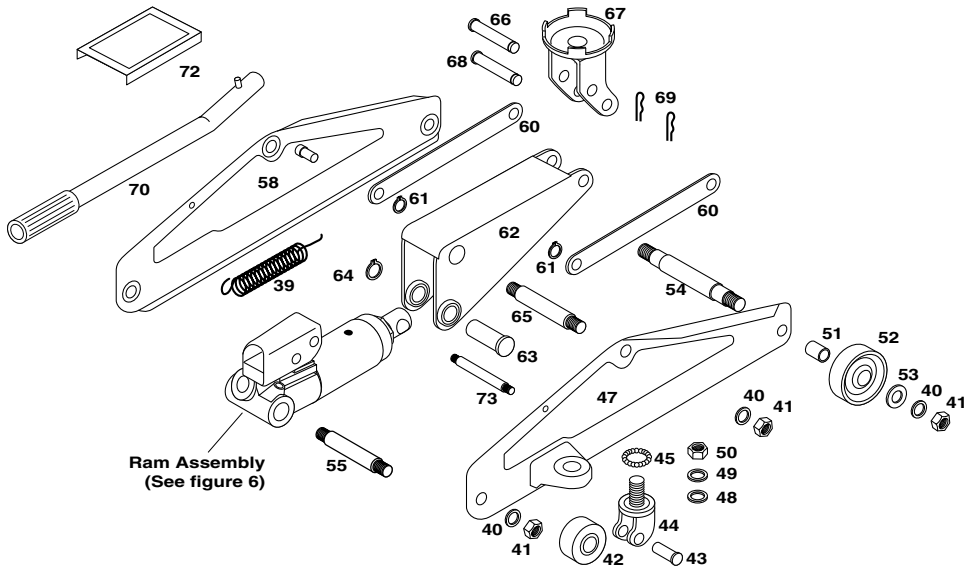

#	Description	Qty. #	Description	Qty. #	Description	Qty.
39	Return Spring	1	51 Front Wheel Spacer	2	65 Lifting Arm Spindle	1
40	Spring Washer	6	52 Front Wheel	2	66 Saddle Mount Pin	1
41	Nut	6	53 Flat Washer	2	67 Saddle Assembly	1
42	Caster Wheel	2	54 Front Wheel Spindle	1	68 Radius Link Pin	1
43	Caster Wheel Spindle	2	55 Body Spindle	1	69 Retaining Pin	2
44	Caster Wheel Fork	2	58 Left Side Member	1	70 Pump Handle	1
45	Steel Ball Bearings	28	60 Radius Link	2	72 Cover Plate	1
47	Right Side Member	1	61 Retaining Ring	2	73 Support Bar	1
48	Flat Washer	2	62 Lifting Arm	1		
49	Lock Washer	2	63 Cross Head Pin	1		
50	Nut	2	64 C 19 Retaining Ring	1		

# REPLACEMENT PARTS LIST - RAM ASSEMBLY

Figure 6

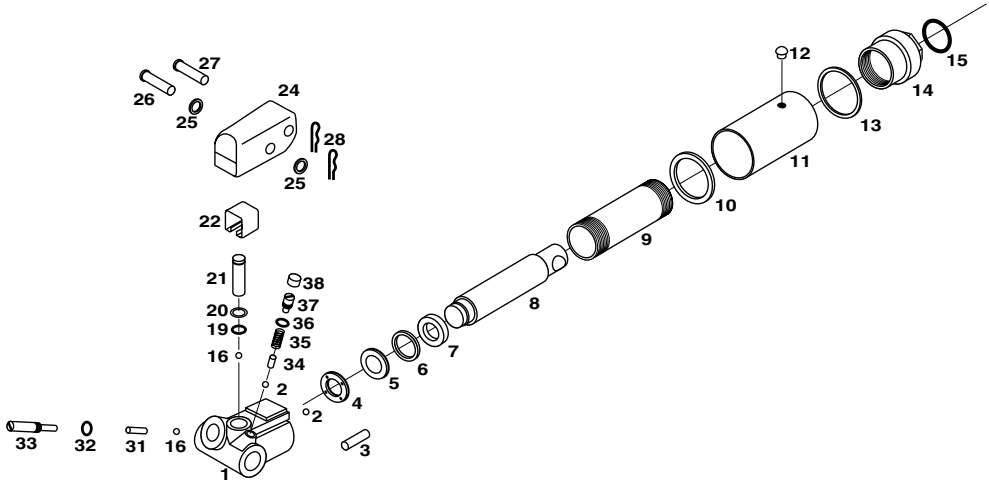

#	Description	Qty.	#	Description	Qty.	#	Description	Qty.
1	Hydraulic Unit Body	1	12	Oil Fill Plug	1	26	Piston Pin	1
2	3/16" Steel Ball	2	13	Fiber Washer (A)	1	27	Connecting Pin	1
3	Filter Body Screen	1	14	Top Nut	1	28	Retaining Pin	2
4	Copper Washer	1	15	Top Nut O-Ring	1	31	Release Valve Spacer	1
5	Pump Cylinder O-Ring	1	16	1/4" Steel Ball	1	32	Release Valve O-Ring	1
6	Back Up Ring	1	19	Pump Cylinder O-Ring	1	33	Release Valve	1
7	Ram Collar	1	20	Back Up Ring	1	34	Spring Guide	1
8	Ram	1	21	Pump Piston	1	35	Overload Valve Spring	1
9	Cylinder	1	22	Piston Clamp	1	36	O-Ring	1
10	Fiber Washer (B)	1	24	Handle Sleeve	1	37	Adjusting Screw	1
11	Oil Chamber	1	25	Piston Washer	2	38	Cap	1

### **1 YEAR LIMITED WARRANTY**

PERFORMANCE TOOL® extends only the following warranties, and only to original retail purchasers. These warranties give specific legal rights. Except where prohibited by local law, the law of the State of Washington governs all warranties and all exclusions and limitations of warranties and remedies. There may be other rights which vary from state to state.

PERFORMANCE TOOL® warrants the product to be free from defects in materials and workmanship under normal use and service. A defective product may be returned for a free replacement within 90 days from the date of purchase, provided that product is returned to place of purchase immediately after discovery of defect. After 90 days and up to one year from date of purchase, PERFORMANCE TOOL® will replace at no charge any parts which our examination shall disclose to be defective and under warranty. These warranties shall be valid only when a sales receipt showing the date of purchase accompanies the defective product or defective part(s) being returned. For part(s) after 90 days, please remit your request, postage prepaid to:

PERFORMANCE TOOL, P.O. Box 88259 Tukwila, WA 98138

These warranties exclude blades, bits, punches, dies, bulbs, fuses, hoses, and other consumables which must be replaced under normal use and service. These warranties shall not apply to any product or part which is used for a purpose for which it is not designed, or which has been repaired or altered in any way so as to affect adversely its performance or reliability, nor shall these warranties apply to any product or part which has been subject to misuse, neglect, accident or wear and tear incident to normal use and service.

PERFORMANCE TOOL® does not authorize any other person to make any warranty or to assume any liability in connection with its products.

Except for warranties of title and the limited express warranties set forth above, PERFORMANCE TOOL® makes no express or implied warranties of any kind with respect to its products. In particular, PERFORMANCE TOOL® makes no implied warranty of merchantability and no implied warranty of fitness for any particular purpose, except that for goods purchased primarily for personal, family or household use and not for commercial or business use, PERFORMANCE TOOL® makes an implied warranty of merchantability (and, if otherwise applicable, an implied warranty of fitness for a particular purpose), but only for the particular qualities or characteristics, and for the duration, expressly warranted above. The laws on limitation of implied warranties may differ from state to state, so the above limitations may not apply in all cases.

PERFORMANCE TOOL® shall not be liable for consequential, incidental or special damages resulting from or in any manner related to any product, or to the design, use, or any inability to use the product. The sole and exclusive remedy for a defective product or part shall be the repair, or replacement thereof as provided above. The laws on limitation of remedies or on consequential, incidental or special damages may vary from state to state, so the above limitations may not apply in all cases.