



# TYGER®

## FENDER FLARE

TG-FF6C4218

PLEASE READ AND FOLLOW THIS APPROVED INSTRUCTION CAREFULLY BEFORE INSTALLATION. FAILURE TO DO SO MAY CAUSE DAMAGE TO THE VEHICLE AND WILL INVALIDATE THE WARRANTY.

### PRIOR TO INSTALLATION

- Remove contents from box. Verify all parts are present and free from any defects or damage.
- Make sure installation is done on a non-abrasive surface to avoid scratching the flare surface.
- Pre-fit each flare to the vehicle body to ensure they suit the profile of the vehicle.
- Remove existing decals and mud flaps on the vehicle that may interfere with flare installation.
- Make sure all flares and fender wheel well are clean as the presence of dirt or sand may scratch auto body paint.
- Suggest removing the tire before installation for easier access.
- Do not use any harsh abrasive detergent to clean the flare.

### PAINTING

Painted flares cannot be returned. Test fit before painting. We are not responsible for any costs that may incur if flares were painted without test fitting.

- Clean surface to be painted with a good grade degreaser. Do not use lacquer thinner or any solvent based product.
- Wipe flare surface completely dry with a tack rag prior to paint.
- Application of plastic adhesion promoter for PP plastic as per your paint system manufacturer's recommendations is required.
- Use a high quality enamel or polyurethane automotive paint to paint the flares.
- Not recommend to paint the edge trim, but if desired use a flex additive.

### WARNING

Dirt or debris may become lodged between flares and vehicle's fenders causing scratching and paint wear from vehicle vibration. TYGER is not responsible for any damage, and installation is done with buyer's understanding that this damage may potentially occur.

### SAFETY INFORMATION

- Before driving, ensure that flare is properly secured to vehicle.
- Do not use automatic "brush-style" car wash.
- Periodically check all components for tightness.

## Hardware Included



[A]

**DAMAGED or MISSING PARTS?**

[www.TygerAuto.com/Contact](http://www.TygerAuto.com/Contact)



## Driver Side Flare Installation

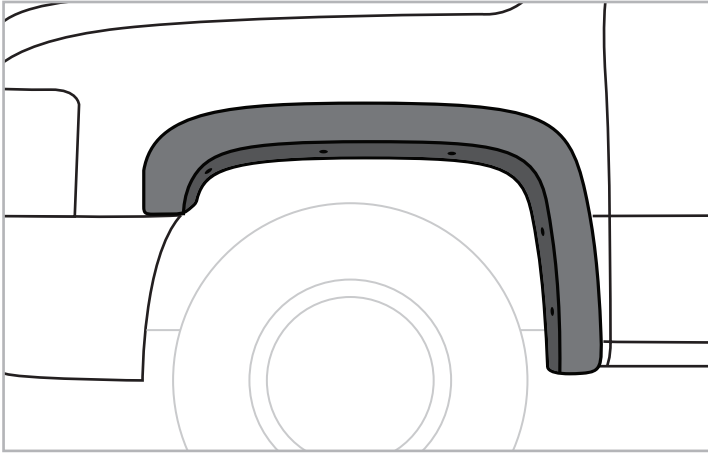

**STEP 1:** Position front flare in place by aligning up holes in flare with vehicle's existing factory holes.

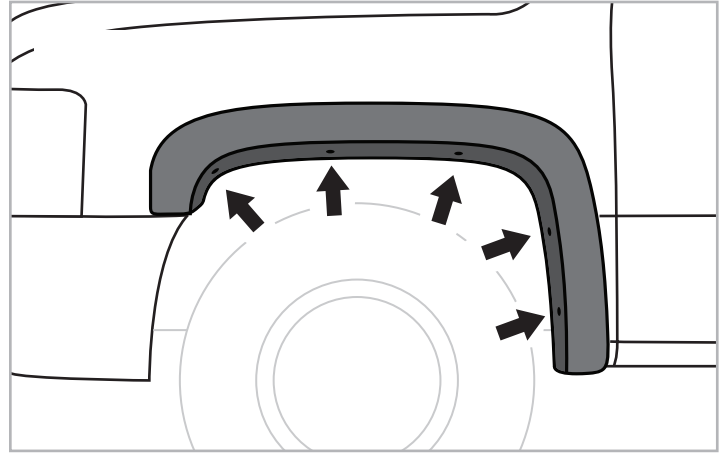

**STEP 2:** Starting at the top center, install 6 supplied Tufloks.

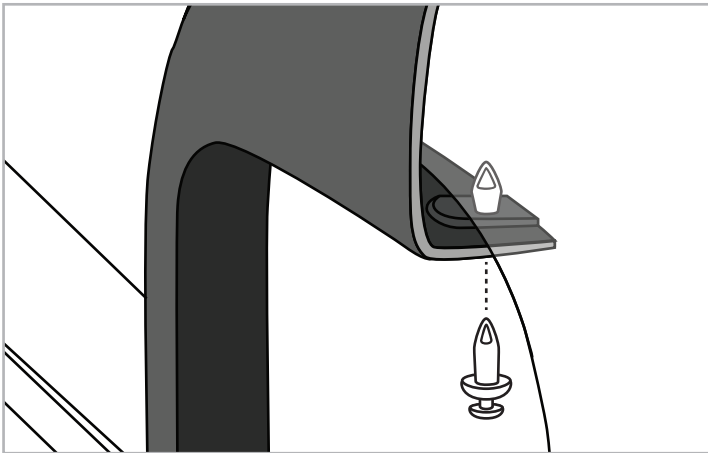

**STEP 3:** Insert the supplied Tuflok [A] through holes in flare and into vehicle's factory holes.

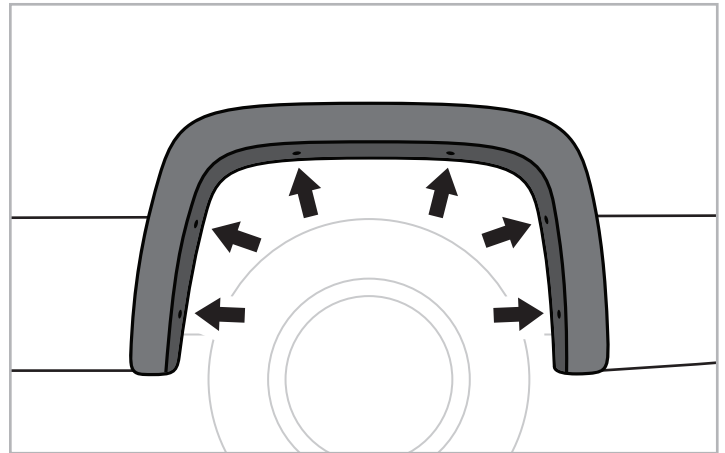

**STEP 4:** Position rear flare in place by aligning up holes in flare with vehicle's existing factory holes.

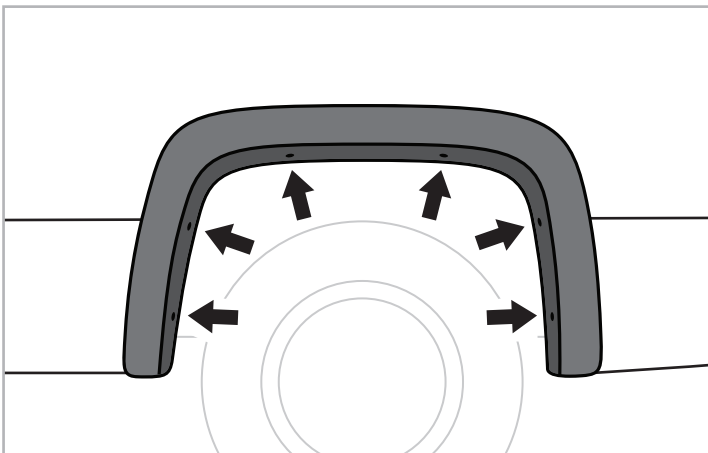

**STEP 5:** Starting at the top center, install 6 supplied Tufloks.

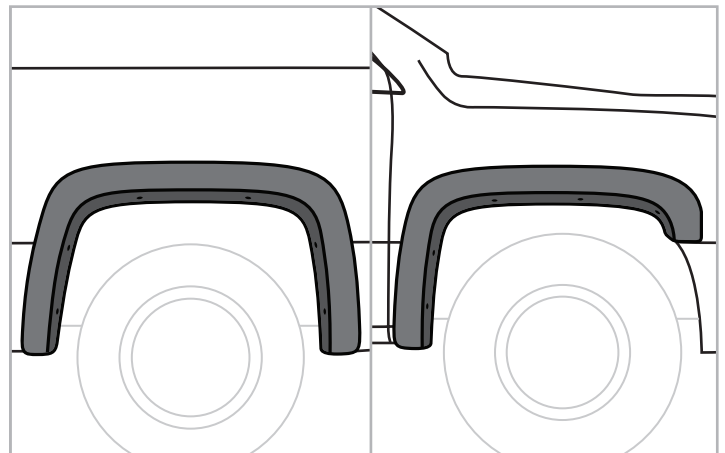

**STEP 6:** Repeat Step 1 to 5 for all other sides.

# FITMENT OR GAP ISSUE?

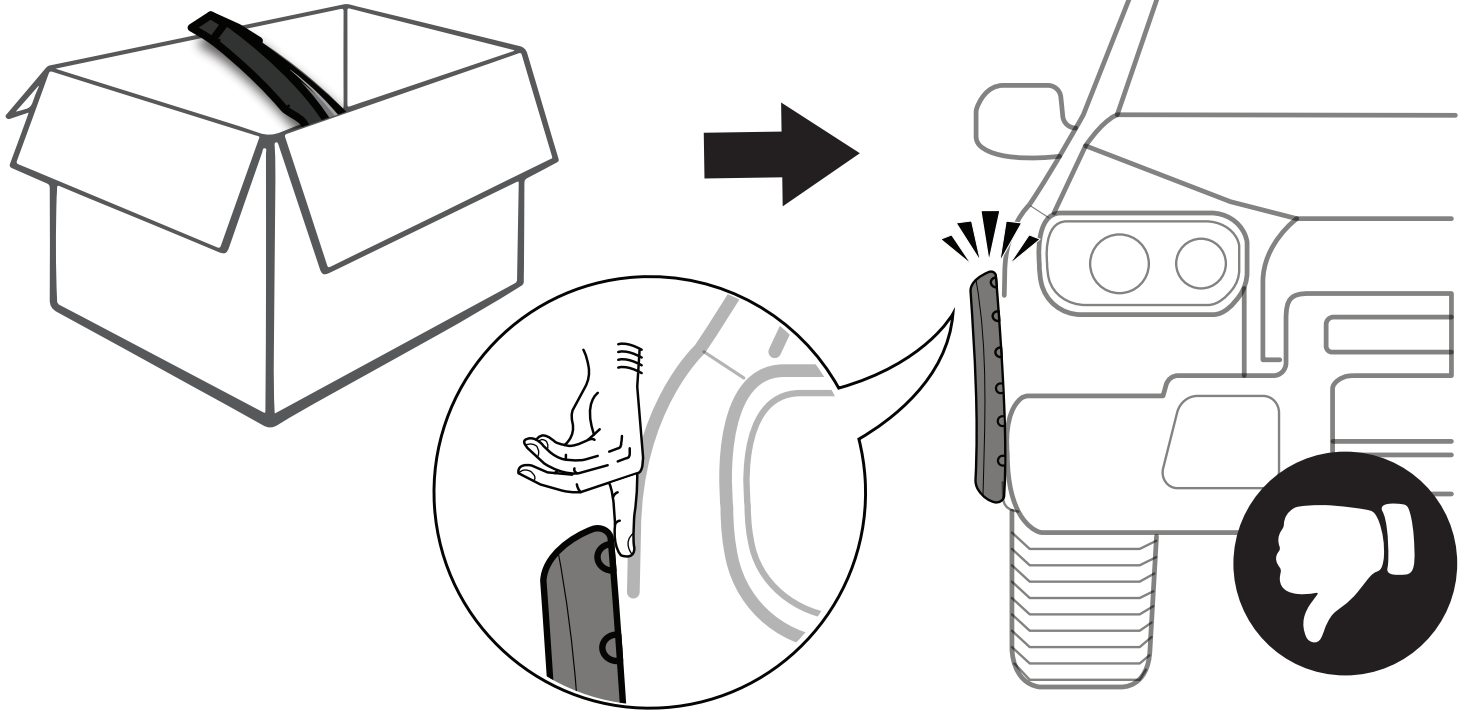

# SOLUTION!

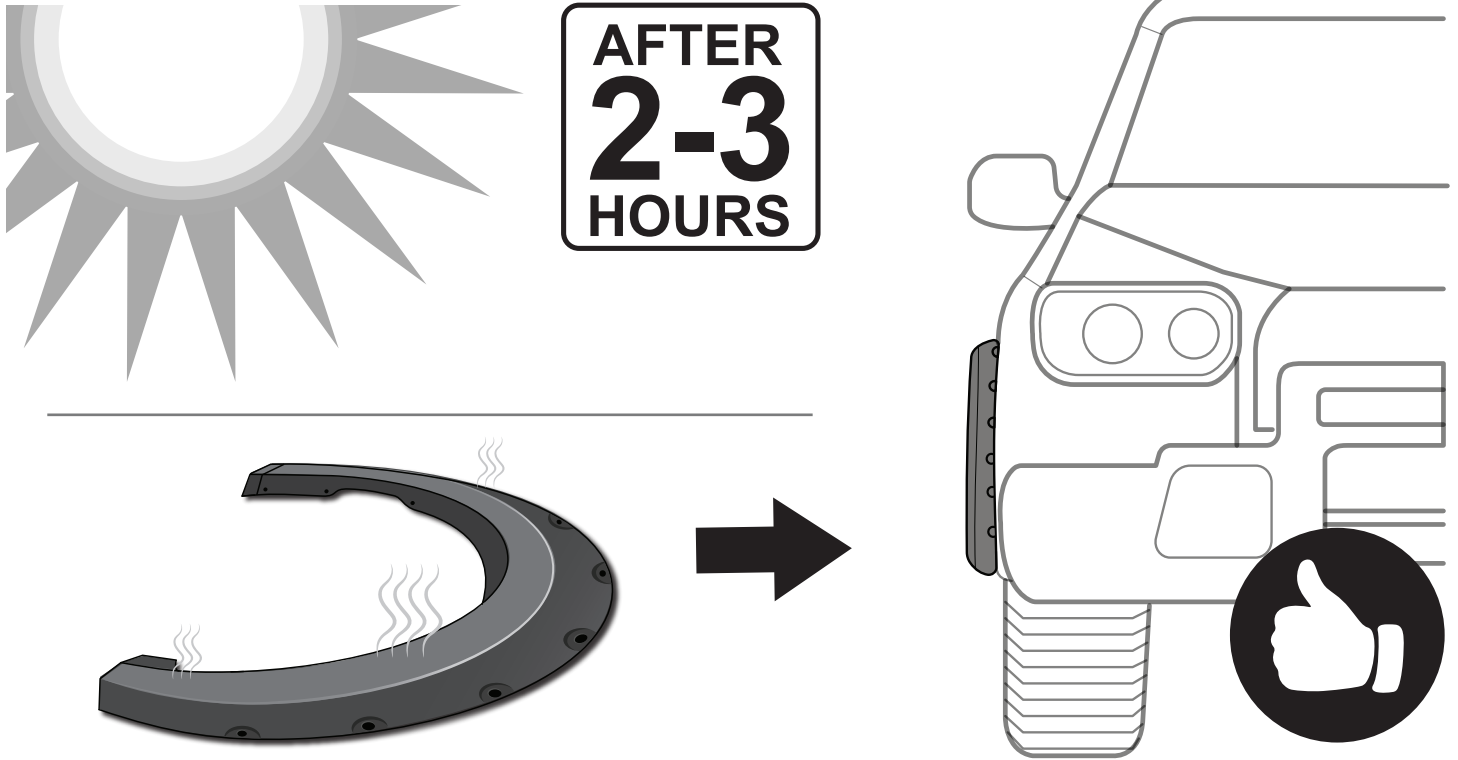

\*In winter, heat gun or hair dryer may be used instead.